

MX3G HMI PLC All-in-One User Manual

Thank you for purchasing Coolmay MX3G HMI PLC All-in-one products. This manual mainly explains the product features, specifications and wiring methods. For detailed PLC programming, please refer to "Coolmay MX3G HMI PLC All-in-one Programming Manual"; for the HMI part, please refer to "Coolmay TP HMI User Manual".

Features of MX3G HMI PLC All-in-one:

1. Super function. The PLC is compatible with FX3S PLC, and the operation speed is fast.
2. Highly integrated. Digital points Max 24 inputs and 24 outputs, digital output optional transistor or mixed output; analog points Max 9 inputs and 2 outputs. Comes with 2 PLC programming ports (RS232/Type-C port) and 1 HMI download port (Type-C port).
3. Support several high-speed counting and high-speed pulse. Acceleration and deceleration are independent; the total of high-speed counting + high-speed pulse cannot exceed 300KHz.
4. Special encryption. HMI and PLC can be encrypted separately, and the PLC password can be set as 12345678 to completely prevent reading the program. [Note: PLC only supports 8-bit password encryption]
5. PLC is compatible with software GX Developer8.86Q and GXWorks2, HMI is TPWorks programming software.
6. The thermocouple input can be customized according to customer requirements. More specifications can be customized in bulk orders.

Product Details

◆ Naming rules

MX3G - 43C - 22 M RT - 4AD 2DA - V - A0 - 1C1 - 1P - 485P/232H

1. Series: MX3G: MX3G series
2. HMI: 43C: 4.3" 50C: 5" 70C: 7"
3. Digital input and output (DI/DO): 22: 12DI 10DO, 32: 16DI16DO, 48: 24DI24DO
4. Module Type: M: General Controller Main Module
5. Digital output type: R: relay, T: transistor, RT: both relay and transistor
6. Analog input (AD): 43C defaults to 5AD, 50C defaults to 3AD, 70C can be customized to 9AD
7. Analog output (DA): 43C defaults to 1 channel voltage + 1 channel current output, 70C defaults to 2 channel current output
8. Analog input type: E: Thermocouple E (type K/T/S/J can be customized, support negative temperature) NTC: Thermistor (10K) A0: 0-20mA current V: 0-10V voltage
9. Analog output type: A0: 0-20mA current V: 0-10V voltage
10. C1: single-phase high-speed counting, C2: AB phase counting, C3: ABZ phase counting
Generally 2 channels single phase 60KHz + 4 channels 10KHz or 1 channel AB (Z) phase 30KHz + 1 channel AB (Z) phase 5KHz
11. P0: high-speed pulse 10KHz; P: high-speed pulse 100KHz; generally 4 channels, Y0-Y1 is 100KHz, 70C: Y2-Y3 is 50KHz, 43C/50C: Y2-Y3 is 10KHz. The total of high-speed counting + high-speed pulse cannot exceed 300KHz
12. Optional COM port, refer to [Chart 1: Basic parameter]

Chart 1: Basic parameter

| Specifications of HMI PLC all-in-one | Digital points | | Analog points | | COM port | | High-speed counting | | | High-speed pulse |
|--------------------------------------|----------------|----|---------------|----|---|--------------------|---|---|---|--|
| | DI | DO | AD | DA | HMI | PLC | Single phase | AB phase | ABZ phase | Output |
| MX3G-43C-22MRT/22MT | 12 | 10 | 5 | 2 | The HMI of 43C/50C comes with 1 RS232; The HMI of 7C HMI comes with 1 RS232 or can be customized as 1 RS485 | Comes with 1 RS485 | Generally single-phase 2 channels 60KHz+4 channels 10KHz; | General-ly AB phase 1 channel 30KHz+1 channel 5KHz; | Generally ABZ phase 1 channel 30KHz+1 channel 5KHz; | Generally 4 channels: Y0-Y1 is 100KHz, Y2-Y3 of 70C is 50KHz, Y2-Y3 of 43C/50C is 10KHz; |
| MX3G-50C-32MRT/32MRT | 16 | 16 | 3 | / | | | | | | |
| MX3G-70C-48MT/48MRT | 24 | 24 | 5 | 2 | | | | | | |

50C digital fixed MT (transistor) output, load 0.2A/point, no relay output;
43C Y0, Y1 and 70C Y0-Y13 fixed MT (transistor) output, load 0.1A/point; other conventional MT transistor output, load maximum 500mA; MR is relay output, load maximum 5A; MRT is mixed output, according to customer optional equipment required.
50C analog input comes with 1 voltage 0-10V+1 current 0-20MA+1 NTC10K; The 43C/70C analog input comes with 2 circuits of voltage 0-10V+2 circuits of current 0-20MA+1 circuit of NTC10K, the 43C analog output comes with 1 circuit of voltage 0-10V+1 circuit of current 0-20MA, and the 70C analog output comes with 2 circuits of current 0-20MA;

Among them, 43C/70C, which purchases 200 or more products, supports customized 4-way thermocouples (E/K/T/S/J type, supporting negative temperature). Among them, 43C customized thermocouples cannot coexist with the built-in current and voltage.

Chart 2: Electrical parameter

| Electric parameter | |
|---------------------|---|
| Input voltage | DC24V |
| Digital input index | |
| Isolation mode | Photocoupling |
| Input impedance | High-speed input 3.4KΩ Common input 4.3KΩ |

(Continued from above chart)

| Input ON | High-speed input: current>5.8mA/24V | Common input: current >9.9mA/24V |
|------------------------------------|--|----------------------------------|
| Input OFF | High-speed input: current<4.5mA/19V | Common input: current >4mA/17V |
| Filter function | With filter function, the filter time can be set among 0-60ms, defaulted as 10ms | |
| High-speed counting | Generally 2 channels single-phase 60KHz+4 channels 10KHz or 1 channel AB(Z) phase 30KHz+1 channel AB(Z) phase 5KHz | |
| Input level | Passive NPN, common terminal isolation, S/S connected to 24V+ | |
| Digital relay output index | | |
| Max current | 2A/point, 4A/4point COM, 5A/8point COM, 5A/12point COM | |
| Circuit power voltage | DC/AC24V~220V | |
| Circuit insulation | Relay mechanical insulation | |
| On response time | About 10ms | |
| Mechanical life (without load) | 10 million times | |
| Electrical life (rated load) | 300,000 times | |
| Output level | Normally open dry contact output, COM can be connected to positive or negative | |
| Digital transistor output index | | |
| Max current | 50C digital fixed MT output, load 0.2A/point; Y0, Y1 of 43C and Y0-Y13 of 70C are fixed as MT output, load 0.1A/point; Other MT: 0.5A/point, 0.8A/4 points COM, 1.6A/12 points COM | |
| Circuit power voltage | DC24V | |
| Circuit insulation | Optocoupler insulation | |
| Isolation voltage (power-terminal) | 1500VAC | |
| On response time | High-speed output: 10μs; others: 0.5ms | |
| High-speed output frequency | Generally 4 channels, Y0-Y1 of 43C/50C is 100KHz, and Y2-Y3 is 10KHz; Y0-Y1 of 70C is 100KHz, Y2-Y3 is 50KHz | |
| Output level | Y0, Y1 of 43C and Y0-Y13 of 70C are fixed as MT, DC24V active NPN output; others are low-level NPN, COM is connected to negative. | |
| Analog input index | | |
| Input signal | Thermocouple/NTC10K/0-10V/0-20mA | |
| Response time | 1 scanning cycle | |
| Analog input | 0-9 channels | |
| Precision | 12 bits | |
| Analog output index | | |
| Output signal | 0-10V/0-20mA | |
| Analog output | 2 channels | |
| Precision | 12 bits | |
| External port | | |
| COM port | Refer to "Chart 1: basic parameter" | |
| Environment | | |
| Operating temperature | 0°C~50°C | |
| Relative humidity | 5%~95%RH | |
| Storage temperature | -20°C~70°C | |
| Vibrational frequency | 10-57Hz, amplitude 0.035mm; 57Hz-150Hz, acceleration 4.9m/s ² (10 times each in X, Y, and Z directions, total 80 minutes each) | |

Mechanical Design

◆ Installation dimension

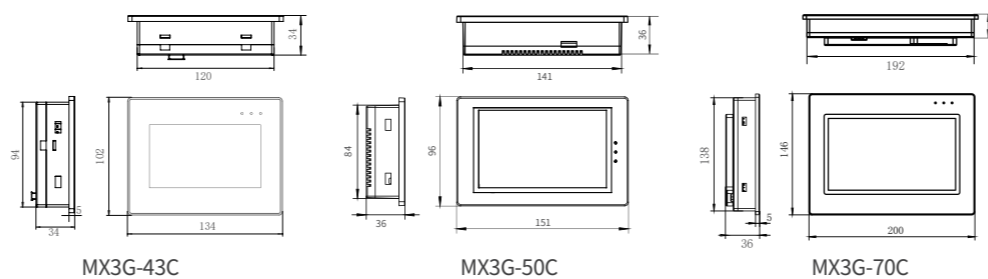

Figure 1 Installation dimension

| Model | Max digital point | Max analog point | Installation dimension | | Dimension W*H*D(mm) |
|----------|-------------------|------------------|------------------------|-------|---------------------|
| | | | A(mm) | B(mm) | |
| MX3G-43C | 12DI/10DO | 5AD/2DA | 120 | 94 | 134*102*34 |
| MX3G-50C | 16DI/16DO | 3AD/0DA | 143 | 86 | 151*96*36 |
| MX3G-70C | 24DI/24DO | 9AD/2DA | 192 | 138 | 210*146*36 |

※ More specifications can be customized for bulk orders

Electric Design

◆ Product structure

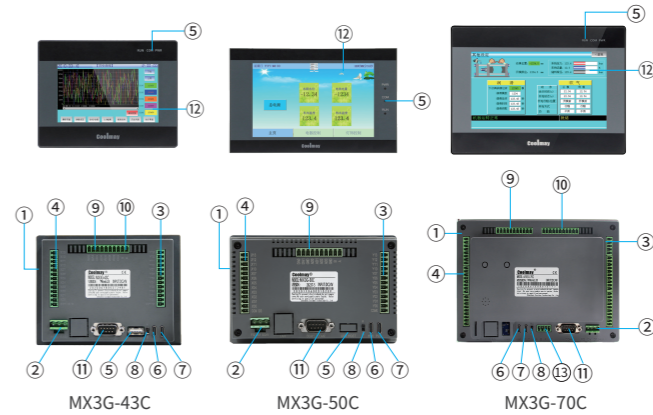

Figure 2 Product structure

- ① Four mounting buckle holes on the side
- ② Terminal block of power supply FG: cover protection GND 0V: 24V negative 24V: 24V positive
- ③ Terminal block of DO
- ④ Terminal block of DI
- ⑤ PWR: power indicator RUN: PLC operating indicator COM: flash when PLC communicates with HMI
- ⑥ HMI programming port (Type-C);
- ⑦ PLC programming port (Type-C)
- ⑧ PLC operating switch RUN/STOP
- ⑨ AD [Note: A/B is RS485]
- ⑩ DA
- ⑪ PLC programming port RS232/HMI default RS232
- ⑫ LCD
- ⑬ PLC/HMI RS485

◆ Hardware interface

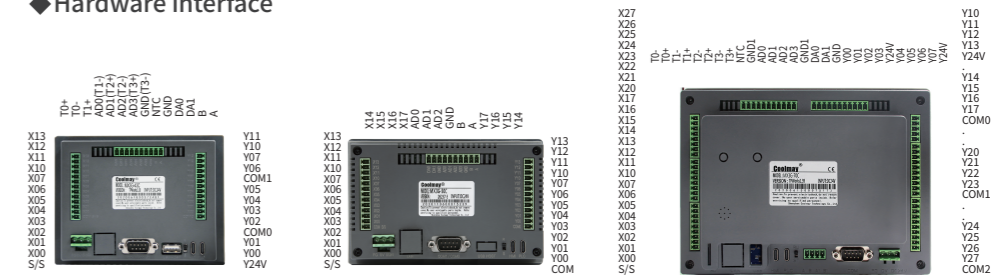

Figure 3 MX3G-43C

Figure 4 MX3G-50C

Figure 5 MX3G-70C

Terminal wiring specifications: 22-14AWG wire. The terminals of this series of models are all pluggable terminals.

Please refer to the product silkscreen for special model interface identification.

COM interface definition: refer to [Chart 4: Pin definition]

| MX3G-43C/50C all-in-one COM | | | | MX3G-70C all-in-one COM | | | |
|-----------------------------|-------------------------|-----------------------|-------------|-------------------------|-----------------------|-------------|---------------------------------------|
| COM1 DB9 port | PLC default | PLC default | HMI default | COM1 DB9□ | PLC default | PLC default | HMI optional |
| PIN# | PLC-485-1 Serial port 2 | PLC-232 Serial port 3 | HMI-232 | PIN# | PLC-232 Serial port 3 | HMI-232 | Cannot coexist with HMI-232 (default) |
| 1 | | | | 2 | √(RXD) | | |
| 6 | | | | 3 | √(TXD) | | |
| 2 | | √(RXD) | | 5 | √(GND) | √(GND) | |
| 3 | | √(TXD) | | 4 | | √(TXD) | |
| 5 | | √(GND) | √(GND) | 7 | | √(RXD) | |
| 4 | | | √(TXD) | 8 | | | |
| 7 | | | √(RXD) | 9 | | | |
| 8 | | | | Terminal A/B | PLC-485 Serial port 2 | | |
| 9 | | | | Terminal A1 B1 | | | HMI-485 |

Chart 4: Pin definition

COM port description:

- ◆ Serial port 2: RS485 (PLC-A, B port): support Mitsubishi programming port protocol, RS protocol and Modbus RTU/ASCII protocol
- ※ Support RS, WR3A, RD3A, ADPRW instructions
- ◆ Serial port 3: RS232 (PLC programming port): supports Mitsubishi programming port protocol, RS2 protocol and Modbus RTU/ASCII protocol
- ※ Support RS2, WR3A, RD3A, ADPRW instructions
- ※ Note: For detailed settings, please refer to "Coolmay MX3G HMI PLC All-in-One Programming Manual"

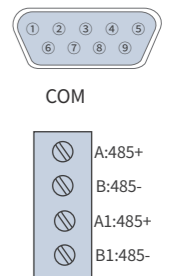

Figure 6 PLC 485 port

Equivalent Circuit

Digital input wiring

PLC input (X) is external power supply DC24V sink type (passive NPN), and the input signal is isolated from the power supply. When in use, it is necessary to connect COM (S/S) to the 24V positive of the power supply.

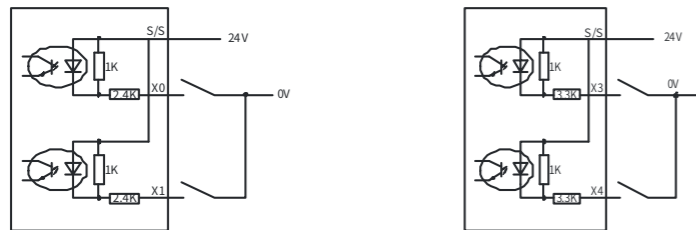

Figure 7 Input wiring (the left one is a high-speed contact, the right one is a normal contact)

PLC digital input wiring:

Port short connection: The S/S of the PLC input terminal is connected to 24V, and the X terminal is connected to the power supply 0V, that is, the input has a signal;
Two-wire system (magnetic control switch): PLC digital input is connected to a two-wire magnetic control switch, the positive pole of the magnetic control switch is connected to the X terminal, and the negative pole is connected to 0V;
Three-wire system (photoelectric sensor or encoder): PLC switch is connected to a three-wire photoelectric sensor or encoder, the power supply of the sensor or encoder is connected to the positive power supply, and the signal cable is connected to the X end; the encoder and photoelectric sensor require NPN type (PNP needs to be specially customized).

PLC digital output wiring:

Transistor: Y0, Y1 of 43C and Y0-Y13 of 70C are fixed as MT output, the wiring load is only 0.1A, and the wiring method is DC24V active NPN output; Other output is NPN, COM is connected to the negative pole, and Y is connected to the positive pole of the power supply after the load.
Relay: dry contact output, COM can be connected to positive or negative.

Digital output wiring

Figure 8 shows the equivalent circuit diagram of the relay output module. The output terminals are in several groups, and each group is electrically isolated. The output contacts of different groups are connected to different power circuits.

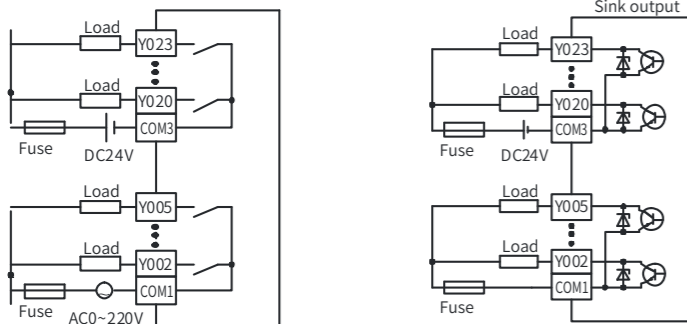

Figure 8 Relay output equivalent circuit

Figure 9 Transistor output equivalent circuit

The PLC output equivalent circuit of the transistor output type is shown in Figure 9. It is also known from the figure that the output terminals are in several groups, and each group is electrically isolated. The output contacts of different groups can be connected to different power circuits; the transistor output can only be used for DC 24V load circuits. The output wiring mode is NPN, COM common cathode. Among them, Y0, Y1 of 43C and Y0-Y13 of 70C are fixed MT output, the wiring load is only 0.1A, and the wiring method is DC24V active NPN output, as shown in Figure 10.

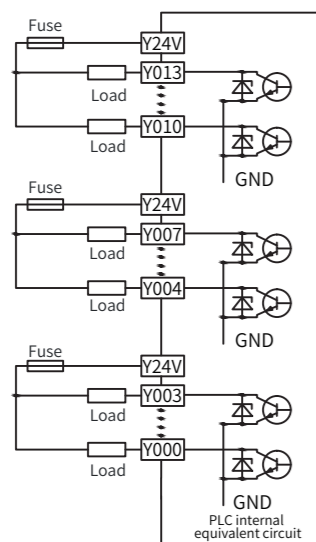

Figure 10 Transistor output equivalent circuit (Y0, Y1 of 43C and Y0-Y13 of 70C)

For the inductive load connected to the AC loop, the external circuit should consider the RC instantaneous voltage absorption circuit; for the inductive load of the DC loop, consider adding a freewheeling diode, as shown in Figure 11.

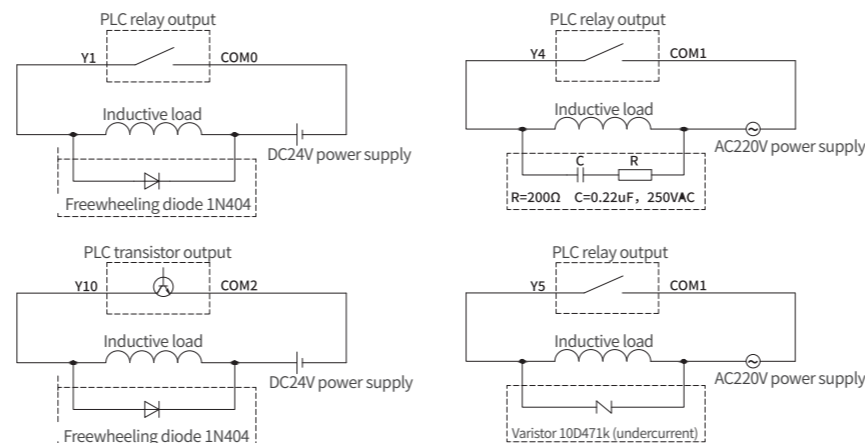
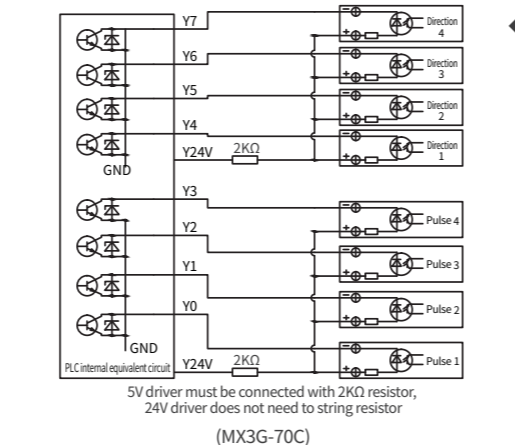
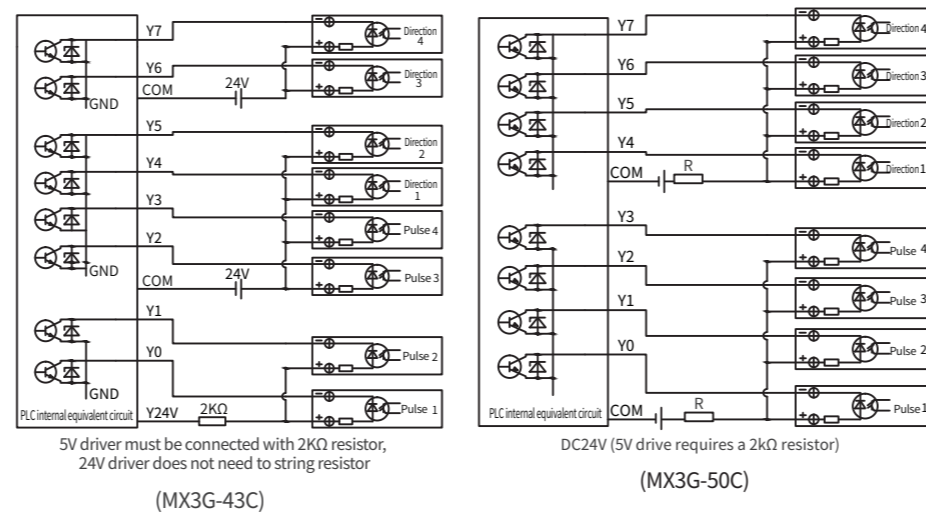

Figure 11 Inductive load absorption circuit

Stepping or servo motor wiring is shown in Figure 12. Y0-Y3 are defaulted as the pulse points of MX3G series PLC (the first 4 channels are output by transistors), and the direction can be customized; Note: 5V drive must connect a 2KΩ resistor on DC24V.



※ Note: All internal circuit in the figures are taken as reference.

Figure 12 Pulse output wiring

MX3G-43C analog input comes with 2 channels of voltage 0-10V+2 channels of current 0-20mA+1 channel of NTC10K or can be customized with 4 channels of EKSTJ type thermocouples (note: thermocouples and built-in voltage and current cannot coexist), and analog output comes with 1 channel of voltage 0-10V+1 channel of current 0-20MA. The temperature wiring is shown in Figure 14.
MX3G-50C analog input comes with 1 voltage 0-10V+1 current 0-20MA+1 NTC10K. The analog input wiring is shown in Figure 13.
MX3G-70C analog input comes with 2 circuits of voltage 0-10V+2 circuits of current 0-20MA+1 circuit of NTC10K, or 4 circuits of EKSTJ type thermocouples can be customized in batch; The analog output comes with 2 circuits of current 0-20MA. The temperature wiring is shown in Figure 15.
Among them, when the thermocouple is not customized, NTC10K can be used as a regular temperature measurement, otherwise it can only be used as a cold end.

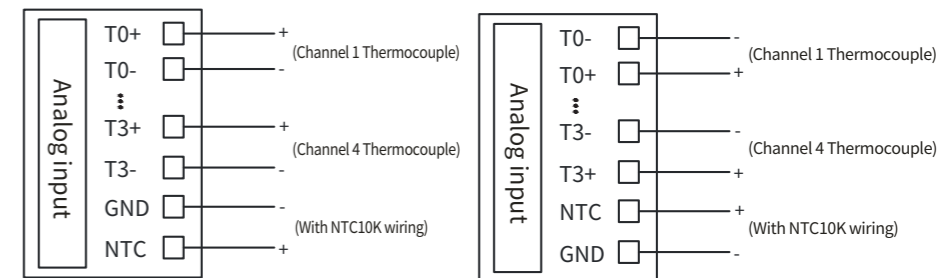

Figure 14 Customized 43C thermocouple wiring

Figure 15 Customized 70C thermocouple wiring

PLC analog wiring

Two-wire system: the positive pole of the power supply is connected to the positive pole of the transmitter, the negative pole of the transmitter is connected to the AD terminal, and the negative pole of the power supply is connected to the GND terminal. Generally, it is the wiring method of the 4-20mA/0-20mA transmitter;
Three-wire system: the positive pole of the power supply is connected to the positive pole of the transmitter, the negative pole of the power supply and the negative pole of the signal output are the same terminal, and the signal output of the transmitter is connected to the AD terminal;
Four-wire system: the positive and negative poles of the power supply are respectively connected to the positive and negative poles of the transmitter, and the positive and negative poles of the transmitter signal output are respectively connected to the AD and GND terminals;
The two wires of the temperature analog quantity are connected to the AD terminal and the GND terminal respectively. The GND common terminal of analog input and output can be shared.

PLC anti-jamming processing

1. Strong electricity and weak electricity should be separated wiring and not common ground. When there is strong electric interference, add magnetic ring on the power supply. And do correct and effective grounding according to the type of the chassis.
2. When the analog is disturbed, 104 ceramic capacitors can be added for filtering, and a correct and effective grounding can be performed.
More details please refer to "Methods of Coolmay PLC anti jamming processing"

The soft elements power retentive of HMI PLC all-in-one is permanently retentive, i.e., all the soft elements in the holding area are not lost if the module is powered off. The real-time clock uses rechargeable battery to ensure that the clock is the current time. All power retentive functions must ensure that the voltage is 23V or higher when DC24V power supply with loads, and the PLC power-on time is longer than 2 minutes. Otherwise, the power retentive functions will be abnormal.

Programming software PLC: compatible with PLC programming software GX Developer 8.86Q and GX Works2

HMI: TP Works HMI programming software

Detailed information, please refer to "Coolmay MX3G HMI PLC All-in-One Programming Manual"

"Coolmay MX3G HMI PLC All-in-One User Manual" "Coolmay TK HMI User Manual"

"Coolmay PLC instruction programming manual"

Tips

MX3G HMI PLC All-in-One User Manual

— Please read carefully the related manuals before using our products, and use this product under the environmental conditions specified in this manual.

- Please confirm the power supply voltage range of this product (Conventional product power supply is only DC24V! Please use a power supply of 18W and above) and connect the power supply correctly to avoid damage.
- When installing this product, please be sure to tighten the screws or clamp the guide rails to avoid falling off.
- Please do not wire or plug or unplug the cable plug when the power is turned on, otherwise it is easy to cause electric shock or circuit damage. Please turn off the power switch immediately when the product emits a peculiar smell or abnormal sound. Do not drop metal shavings and wire ends into the ventilation holes of the controller during screw hole processing and wiring; otherwise, it may cause product failure and misoperation.
- Do not tie the power cord and the communication cable together or put them too close together, should keep them at a distance of more than 10cm; strong and weak currents need to be separated and properly and effectively grounded. In severe interference situations, shielded cables should be used for communication and high-frequency signal input and output cables to improve anti-interference performance. The grounding terminal FG on the machine must be grounded correctly to improve the anti-interference ability.
- The switch input is external power supply DC24V sink type (passive NPN), the input signal is isolated from the power supply, and COM (S/S) needs to be connected to the 24V positive of the external power supply when in use.
- The Y24V of the digital output common terminal is actively output.
- Please do not disassemble the product or modify the wiring at will. Otherwise it may cause failure, malfunction, loss, or fire.
- Please turn off all power when installing and disassembling the product, otherwise it will cause equipment malfunction and error.

Analog wiring

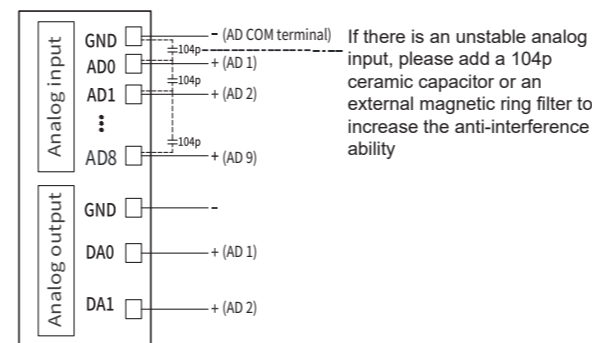

Figure 13 PLC analog wiring

Shenzhen Coolmay Technology Co., Ltd

Tel.: 0755-86950416

86960332

26051858

26400661

Fax: 0755-26400661-808

QQ: 1687435500

Email: m3@coolmay.com

Website: www.coolmayplc.com

Version: 2023/8

Catalog

| | |
|------------------------------|----|
| Tips | 01 |
| Product Features | 02 |
| Product Information | 03 |
| Electric Parameter | 04 |
| Mechanical Design | 05 |
| Electric Design | 06 |
| Equivalent circuit | 07 |
| Analog Wiring | 08 |
| Anti-interference Processing | 09 |
| Programming Reference | 10 |
| Data Reference | 11 |