

Coolmay EX3S-28FH and 8043B All-in-One User Manual

Thank you for purchasing the Coolmay EX3S series all-in-one machine. This manual mainly explains the product characteristics, general specifications, and wiring methods of this series of touch screen PLC all-in-one machines. For detailed PLC programming, please refer to the "Coolmay EX3S-28FH and 8043B All-in-One Programming Manual"; for the touch screen section, please refer to the "Coolmay TK8043B TouchScreen Single-Page Brochure".

The EX3S series touch screen PLC all-in-one machine has the following characteristics:

1. Adopting military grade 32-bit CPU+ASIC dual processors, supporting online monitoring and downloading, the fastest execution speed of basic instructions reaches 0.24us.
2. Highly integrated. The maximum switch quantity is 16 inputs and 16 outputs, and the switch quantity output is a transistor, relay, or hybrid.
3. The communication port HMI can support a maximum of one RS485, and the PLC can support a maximum of two RS485.
4. High-speed counting can reach 6 single-phase or 2 AB phase 100KHz, and the pulse can reach up to 4 100KHz.
5. The PLC program has a capacity of 30K steps, 12K hold registers, and supports programming languages such as instructions, ladder diagrams (LD), and step ladder diagrams (SFC).
6. Supports multiple interrupts, including input interrupts, timer interrupts, and counter interrupts, totaling 15 interrupt points.
7. Can be specially encrypted. The touch screen and PLC can be encrypted separately, and setting the PLC password to 12345678 can completely prohibit program reading.
8. Easy wiring. All wiring terminals adopt 3.81 pitch pluggable terminals, which are convenient for customers to use.

Production information

◆ Naming rules EX3S -28FH/8043B - 24 M T - 4AD 2DA - 485/232P

1. Company product series EX3S: Coolmay economical touch screen PLC all-in-one machine
2. HMI type 28FH: 2.8-inch standard 8043B: 4.3-inch alt. cutout
3. Input/output points 16: 8DI8DO 24: 12DI12DO 32: 16DI16DO
4. Module classification M: General controller main module
5. Switch output type R: Relay output type; T: Transistor output type; RT: Hybrid output of transistor and relay
6. The maximum number of analog input points is 8
7. The maximum number of analog output points is 2
8. Analog input type E: E-type thermocouple (optional K/T/S/J types, supports negative temperatures) PT: PT100 PT1000: PT1000 V: 0-10V V5: 0-5V A0: 0-20mA A4: 4-20mA
9. Analog output type V: 0-10V A0: 0-20mA
10. The communication port 485/232P indicates optional 485/232 on the PLC; 485/232H indicates optional 485/232 on the touch screen

◆ Table 1: Basic Parameters

Common models and specifications	Digital		Analog		COM.Port		High-speed counting		High-speed pulse
	DI	DO	AD	DA	HMI	PLC	single-phase	AB phase	Output
EX3S-28FH-16MT	8	8	Up to 5 channels	/	/	Comes with 1 RS485	Conventional single-phase 6-channel 100KHz	Conventional AB phase 2-channel 100KHz	Conventional 4-channel Y0-Y3 is 100KHz
EX3S-8043B-32MT	16	16	/	/	Comes with 1 RS485	Comes with 2 RS485			
EX3S-8043B-24MRT	12	12	Fixed 4 channels	2					/

1. EX3S-28FH-16MT analog input type is available in three models: ① 1-channel NTC 10K + 2-channel voltage 0-10V + 2-channel current 0-20mA; ② 4-channel thermocouple (AD4 needs to be replaced with cold junction); ③ 4-channel PT100 + 1-channel NTC 10K
2. EX3S-8043B-24MRT has fixed 2-channel voltage 0-10V + 2-channel current 0-20mA analog inputs and 2-channel voltage 0-10V/current 0-20mA analog outputs as needed;
3. High-speed counting and pulse limitation notes: X5 and Y3 cannot be used simultaneously for high-speed counting and high-speed pulse output, but both can be used as regular input/output points.

◆ Table 2: Electrical Parameters

Electrical parameters	
Input voltage	DC24V
Digital input indicators	
Isolation method	Photoelectric coupling
Input impedance	High speed input terminal 2.4K Ω Normal input terminal 3.3K Ω
Input-ON	The input current at the high-speed input terminal is greater than 5.8mA/24V The input current of the ordinary input terminal is greater than 9.9mA/24V
Input-OFF	The input current at the high-speed input end is less than 4.5mA/19V The input current of the ordinary input terminal is less than 4mA/17V
Filtering function	With filtering function, the filtering time can be set within the range of 0-60ms, with a default of 10ms
High speed counting function	Conventional single-phase 6-channel 100KHz or AB phase 2-channel 100KHz
Input voltage level	Passive NPN or PNP, common terminal isolation
Digital relay output indicators	
Maximum output current	Load 2A/point, 8A/12 points COM; Mixed output loads 2A/point, 8A/4 points COM

(Connect to the table)

Circuit power supply voltage	250 V AC/30V DC
Circuit insulation	Relay mechanical insulation
On response time	About 10ms
Mechanical lifespan (no load)	10 million times
Electrical lifespan (rated load)	100000 times
Output level	Constant open dry contact output, COM can be connected to positive or negative

Digital transistor output indicators	
Maximum output current	Load 0.5A/point, 4A/12 points COM; Mixed output loads 0.5A/point, 2A/4 points COM, 4A/8 points COM
Circuit power supply voltage	DC24V
Circuit insulation	Optocoupler insulation
Isolation voltage (power supply external terminal)	1500VAC
On response time	High-speed output: 10us; other: 0.5ms
High speed output frequency	MT output: Conventional 4-channel Y0-Y3 at 100KHz
Output level	Low level NPN, COM connected to negative

Analog input indicators	
Input signal	0-10V/0-20mA/Thermocouple/PT100
Response time	1 scanning cycle
Analog input points	Maximum 5 channels
Accuracy	12 bits
Analog output indicators	
Output signal	0-10V/0-20mA
Analog output points	2 channels
Accuracy	12 bits

External Interface	
COM.Port	EX3S-28FH-16MT: PLC comes with one RS485; EX3S-8043B: HMI comes with one RS485 interface; PLC comes with two RS485

Ambient condition	
Operation temperature	-20°C~50°C
Relative humidity	5%~95%RH
Storage temperature	-20°C~70°C
Vibration frequency	10-57Hz, amplitude 0.035mm; 57Hz-150Hz, acceleration 4.9m/s ² (10 times in each of the X, Y, and Z directions, totaling 80 minutes each)

Mechanical Design Reference

◆ Installation size

EX3S-28FH-16MT:

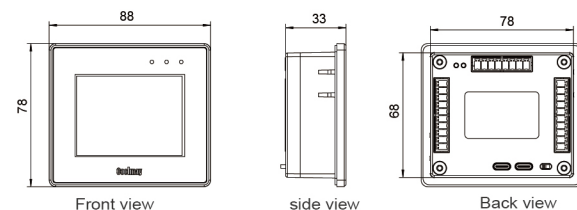

EX3S-8043B-24MRT/32MT:

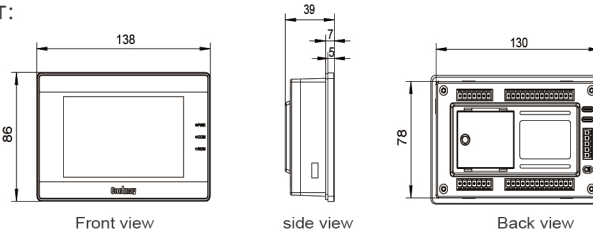

Figure 1 Installation dimension diagram

◆ Table 3: Dimensional Table

Model	MAX digital	MAX analog	Installation size		External dimensions W*H*D(mm)
			A(mm)	B(mm)	
EX3S-28FH-16MT	8DI8DO	5AI	80	70	88*78*33
EX3S-8043B	16DI16DO	4AI2AO	132	80	138*86*39

Electrical Design Reference

◆ Product structure

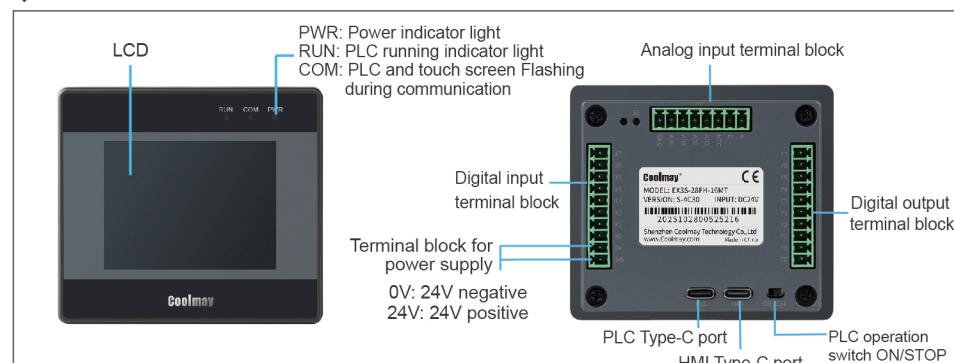

Figure 2 EX3S-28FH-16MT Product Structure

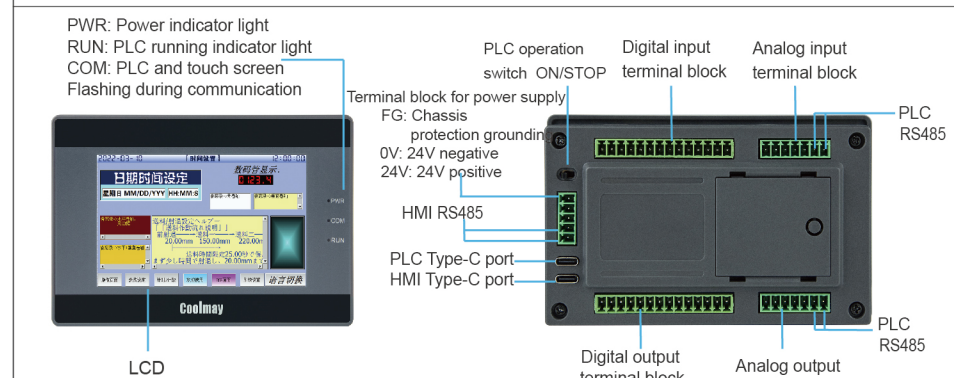

Figure 3 EX3S-8043B Product Structure

◆ Hardware interface

EX3S-28FH-16MT		EX3S-8043B-24MT/32MRT	
GND AD0 AD1 AD2 AD3 NTC B A	X7 X6 X5 X4 X3 X2 X1 X0 0V 24V	24MRT: S/S X00 X01 X02 X03 X04 X05 X06 X07 X10 X11 X12 X13 GND V11 V12 V2 A1 B1 32MT: S/S X00 X01 X02 X03 X04 X05 X06 X07 X10 X11 X12 X13 S/S X14 X15 X16 X17 A1 B1	Y7 Y6 Y5 Y4 C1 Y3 Y2 Y1 Y0 C0
		24MRT: C0 Y00 Y01 Y02 Y03 Y04 Y05 C1 Y06 Y07 Y10 Y11 Y12 Y13 GND V01 I01 V02 I02 A B 32MT: C0 Y00 Y01 Y02 Y03 Y04 Y05 C1 Y06 Y07 Y10 Y11 Y12 Y13 C2 Y14 Y15 Y16 Y17 A1 B1	

Figure 4 EX3S-28FH-16MT

Figure 5 EX3S-8043B-24MT/32MRT

Terminal wiring specification: 22-14AWG wire. The terminals of this series of models are all pluggable terminals. Please refer to the product silk screen for the identification of special model interfaces.

◆ Definition of communication port pins for all-in-one machines

EX3S-28FH-16MT all-in-one machine, with a built-in RS485 on the touch screen; The PLC comes with one RS485 (A, B); EX3S-8043B all-in-one machine, with a built-in RS485 on the touch screen; The PLC comes with two RS485

As shown in the table below:

Instructions for the COM port of EX3S-28FH-16MT		
Terminal	Definition	Illustrate
Terminal A	485+	PLC-RS485 (Serial port 2)
Terminal B	485-	

EX3S-8043B款通讯口说明		
Terminal	Definition	Illustrate
Terminal A	485+	PLC-RS485 (Serial port 2)
Terminal B	485-	
Terminal A1	485+	PLC-RS485 (Serial port 3)
Terminal B1	485-	
Terminal A2	485+	HMI-RS485 (Serial port 1)
Terminal B2	485-	



Figure 6 PLC485 Port

◆ Communication port description:

- ◆ PLC communication port: Supports Mitsubishi programming port protocol, free port protocol, and Modbus RTU/ASCII protocol
- ※ Note: For detailed communication procedures, please refer to the "Coolmay EX3S-28FH and 8043B All-in-One Programming Manual"

Equivalent circuit

◆ Digital input wiring circuit

The input of the EX3S series all-in-one machine is a biphasic optocoupler, and the input signal is isolated from the power supply, with passive input; Users can choose NPN or PNP connection method. However, it should be noted that since the common terminals of the input points are all connected, a product can only have one wiring method and cannot be mixed.

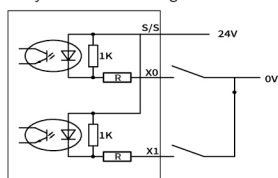

Figure 7 Input (NPN) wiring diagram

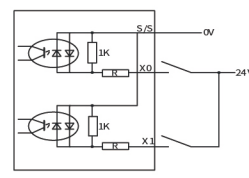

Figure 8 Input (PNP) wiring diagram

PLC digital NPN input wiring:

Port short circuit: The S/S of the PLC input terminal is connected to 24V, and the X terminal is connected to the power supply 0V, indicating that there is a signal input; Two wire system (magnetic control switch): PLC switch input is connected to a two-wire magnetic control switch, with the positive pole of the magnetic control switch connected to the X terminal and the negative pole connected to 0V;

Three wire system (photoelectric sensor or encoder): The PLC switch is connected to the photoelectric sensor or encoder of the three wire system. The power supply of the sensor or encoder is connected to the positive pole of the power supply, and the signal line is connected to the X terminal; Encoders and photoelectric sensors require NPN type.

PLC digital PNP input wiring:

Port short circuit: The S/S of the PLC input terminal is connected to 0V, and the X terminal is connected to the 24V power supply, indicating that there is a signal input; Two wire system (magnetic control switch): PLC switch input is connected to a two-wire magnetic control switch, with the negative pole of the magnetic control switch connected to the X terminal and the positive pole connected to 24V;

Three wire system (photoelectric sensor or encoder): The PLC switch is connected to the photoelectric sensor or encoder of the three wire system. The power supply of the sensor or encoder is connected to the positive pole of the power supply, and the signal line is connected to the X terminal; The encoder and photoelectric sensor require PNP type.

◆ Digital output wiring circuit

Figure 9 shows the equivalent circuit diagram of the relay output module, with several groups of output terminals that are electrically isolated from each other. The output contacts of different groups are connected to different power circuits.

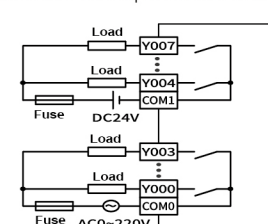

Figure 9 Equivalent circuit of relay output

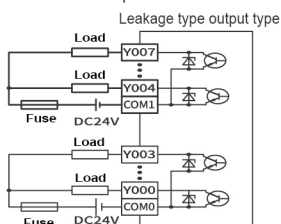

Figure 10 Equivalent circuit of transistor output

The equivalent circuit of the output part of the transistor output type PLC is shown in Figure 10. As can also be seen from the figure, the output terminals are divided into several groups, and each group is electrically isolated. The output contacts of different groups can be connected to different power circuits; The transistor output can only be used for DC 24V load circuits. The output wiring method is NPN, COM common cathode.

For inductive loads connected to AC circuits, external circuits should consider RC instantaneous voltage absorption circuits; For the inductive load of the corresponding DC circuit, consideration should be given to adding a freewheeling diode, as shown in Figure 11. The wiring of the stepper or servo motor is shown in Figure 12. The PLC defaults to Y0-Y3 as pulse points, and the direction can be customized;

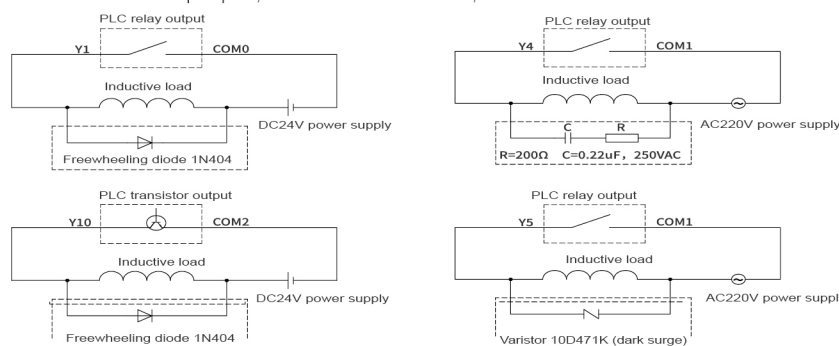

Figure 11 Schematic diagram of inductive load absorption circuit

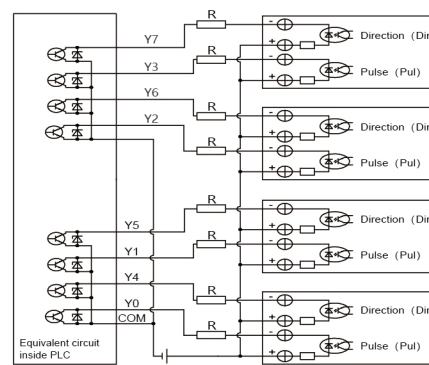

Figure 12 Pulse output wiring diagram

※ Note: All internal circuits shown in the diagram are for reference only

◆ PLC analog wiring

Two-wire system: the positive pole of the power supply is connected to the positive pole of the transmitter, the negative pole of the transmitter is connected to the AD terminal, and the negative pole of the power supply is connected to the GND terminal. Generally, the wiring method for 4-20mA/0-20mA transmitters is used;

Three-wire system: the positive pole of the power supply is connected to the positive pole of the transmitter, the negative pole of the power supply and the negative pole of the signal output are the same terminal, and the signal output of the transmitter is connected to the AD terminal;

Four-wire system: The positive and negative poles of the power supply are connected to the positive and negative poles of the transmitter respectively, and the positive and negative poles of the transmitter signal output are connected to the AD terminal and GND terminal respectively.

* If there is an unstable analog input, please add a 104p ceramic capacitor or an external magnetic ring filter as appropriate to increase anti-interference ability.

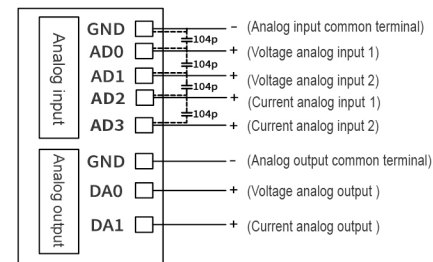

Figure 13 PLC Analog Output Wiring

EX3S-8043B has 4 fixed analog inputs and 2 fixed analog outputs. The negative terminals are connected to the GND of the analog input/output terminals respectively. For input and output types, refer to Table 1, as shown in Figures 13.

PLC anti-interference processing

1. Strong and weak electricity should be wired separately and cannot be grounded together; When there is strong electrical interference, add a magnetic ring at the power supply end; And carry out correct and effective grounding treatment according to the type of casing.

2. When the analog signal is disturbed, a 104 ceramic capacitor can be added for filtering and correctly and effectively grounded.

※ For more detailed information, please refer to the official website "PLC anti-interference processing methods"

Programming reference

◆ Software component allocation and power-off maintenance instructions

Max digitals	EX3S-28FH-16MT	EX3S-8043B-24MRT	EX3S-8043B-32MT
Digital input X	X00~X07 8 points	X00~X13 12 points	X00~X17 16 points
Digital output Y	Y00~Y07 8 points	Y00~Y13 12 points	Y00~Y17 16 points
Auxiliary relay M	[M0~M383] 384 points for general use/ [M384~M1535] 1152 points for holding use/ [M1536~M7679] 6144 for general use/ [M8000~M8511] 512 points for special use		
Status S	[S0~S9] 10 points for initial state/ [S10~S999] 990 points for holding use/ [S1000~S4095] 3096 points for general use		
Timer T	[T0~T199] 200 o'clock 100ms for general use/ [T200~T245] 46 o'clock 10ms for holding use		
	[T246~T249] 4 o'clock 1ms cumulative type/ [T250~T255] 6 o'clock 100ms cumulative type		
	[T256~T511] 256 o'clock 1ms for general use ※The 10ms timer will be affected by the scanning cycle. If the scanning cycle is 12ms, the timer will execute once every 12ms.		
Counter C	16-bit up counter	32-bit up/down counter	high-speed counter
	[C0~C15] 16 points for general use [C16~C199] 184 points for holding use	[C200~C219] 20 points for general use [C220~C234] 15 points for holding use	[C235~C245] single-phase single counting [C246~C250] single-phase dual counting [C251~C255] dual-phase dual-counting
Data Register D	[D0~D127] 128 points for general use/ [D128~D7999] 7872 points for holding use/ [D8000~D8511] 512 points for special use		
Data registers V, Z	[V0~V7] [Z0~Z7] 16 points for addressing purposes		
Counter JUMP, CALL for branches	[P0~P4095] 4096 points		
Nesting	[N0~N7] 8 points for main control		
Interruption	[I00~I500] Used for 6-point input interruption/ [I600~I800] Used for 3-point timer interruption/ [I10~I1060] Used for 6-point counter interruption		
Constant	K	16-bit -32,768~32,767	32-bit -2,147,483,648~2,147,483,647
	H	16-bit 0000~FFFF	32-bit 00000000~FFFFFFFF

◆ Analog input register (AD stands for analog input) with an accuracy of 12 bits supports direct reading of registers:

D [8030]~D [8034] are the input values corresponding to the analog quantities [AD0~AD4], channel switch D8114;

- EX3S-28FH-16MT analog input type comes in 3 models: ① 1-channel NTC 10K +2-channel voltage 0-10V+2-channel current 0-20mA; ② 4-channel thermocouple (AD4 needs to be replaced with cold junction); ③ 4-channel PT100 + 1-channel NTC 10K
- EX3S-8043B all-in-one machine has fixed analog inputs of 2-channel voltage 0-10V and 2-channel current 0-20mA

NO.	Register reading value	Channel switch register
AD0	D8030	Started when D8114.0~D8114.4=1
AD1	D8031	
AD2	D8032	
AD3	D8033	
AD4	D8034	

◆ Sampling of analog input

D8073 is the number of sampling periods: range 0-7, default=7; After modification, restart to take effect. If D8073=1, then one PLC scanning cycle samples once and changes the value in the analog input once. D8100 is the number of filtering cycles: range 0-32767, default value=5.

※ Note: For the analog input range and corresponding register values, please refer to the "Coolmay EX3S-28FH and 8043B All-in-One Programming Manual".

◆ Analog output register (DA represents analog output, with an accuracy of 12 bits); Support direct register assignment operation

- 8043B has 2-channel voltage 0-10V or current 0-20MA output, wired as needed.

No.	Register address	Range of set values	Description
DA0	D8050	0-4000	Write value automatic conversion output
DA1	D8051	0-4000	

The soft components of the touch screen PLC all-in-one machine are permanently held when the module is powered off, that is, all soft components in the holding area are not lost after the module is powered off; All power-off hold functions must ensure that the voltage of the DC24V power supply with load is above 23V, and the power on time of the PLC is greater than 2 minutes, otherwise abnormal power-off functions may occur.

Programming software: PLC: Coolmay VTool Pro Programming Software HMI: Coolmay TPWorks Touchscreen Programming Software For detailed information, please refer to the "Coolmay EX3S-28FH and 8043B All-in-One Programming Manual" and "Coolmay TK80 Series Touchscreen User Manual".

TIPS

EX3S series all-in-one user manual

— Before using this product, please carefully read the relevant manual and use it under the environmental conditions specified in the manual.

- Please confirm the power supply voltage range of this product (conventional product power supply is limited to DC 24V! It is recommended that the output power of the power supply be 18W or above) and correct wiring before powering on to avoid damage.
- When installing this product, please be sure to tighten the screws or clamp the guide rail to avoid detachment.
- Avoid wiring and plugging cable plugs when they are live, as this can easily cause electric shock or circuit damage; When the product emits an odor or abnormal sound, please immediately disconnect the power switch; When machining screw holes and wiring, do not let the metal wire end fall into the ventilation hole of the controller, as this may cause product failure and misoperation.
- Do not tie the power cord and communication cable together or place them too close. Keep a distance of at least 10cm; Strong and weak electricity need to be separated and properly and effectively grounded; In situations with severe interference, shielded cables should be used for communication and high-frequency signal input and output to improve anti-interference performance. The grounding terminal FG on this machine must be correctly grounded to improve its anti-interference ability.
- The switch input is powered by external DC24V, and the input signal is isolated from the power supply. It supports PNP or NPN connection and can choose one wiring method during use. It does not support mixed connection, otherwise it may cause damage to the machine.
- Switching output includes transistors and relays, and different types have different common terminal connections. Attention should be paid when using them.
- Please do not disassemble the product or modify the wiring at will. Otherwise, it may cause malfunctions, misoperations, losses, and fires.
- When installing and disassembling the product, please be sure to cut off all power sources, otherwise it will cause equipment malfunction and failure.

Product Warranty Statement

Dear customer:

Sincerely thank you for choosing this product. As our user, you will receive our company's high-quality service of "free repair service and lifelong technical support for product quality problems caused by non-human damage or disassembly within two years from the date of purchase (one and a half years for LCD screen and touchpad).

During the warranty period, if there is a hardware malfunction caused by the product itself, our company will provide customers with free replacement or repair services. Please do not disassemble and repair the product yourself. Our products are labeled with anti-disassembly labels, and only our company and authorized professionals can repair our products. Any unauthorized disassembly and repair of the product by other personnel is equivalent to automatically waiving the warranty services provided by our company.

Situations not covered by the free warranty service:

- Damage caused by human factors (external impact or collision, improper use, etc.)
- The product has been disassembled, modified, or repaired without authorization
- Damage caused by external factors such as lightning strikes, water ingress into the power supply, and falls
- Damage caused by incorrect installation or use by the user
- The device has exceeded the warranty service period

If you need to repair, please fill in the following items:

Product Name: _____ Customer Name: _____
 Product model: _____ contact number: _____
 Product serial number: _____ Purchase date: _____
 Problem remarks: _____

Shenzhen Coolmay Technology Co., Ltd

Tel: +86 19925291353
 Email: cm2@coolmay.net
 Web: en.coolmay.com



Alibaba



AliExpress

V2025/ 11

The model specifications and information related to the product in this manual are subject to change without prior notice